

Füllhöhe = 95% der Tankinnenhöhe! / Body stand = 95% middle high of tank!

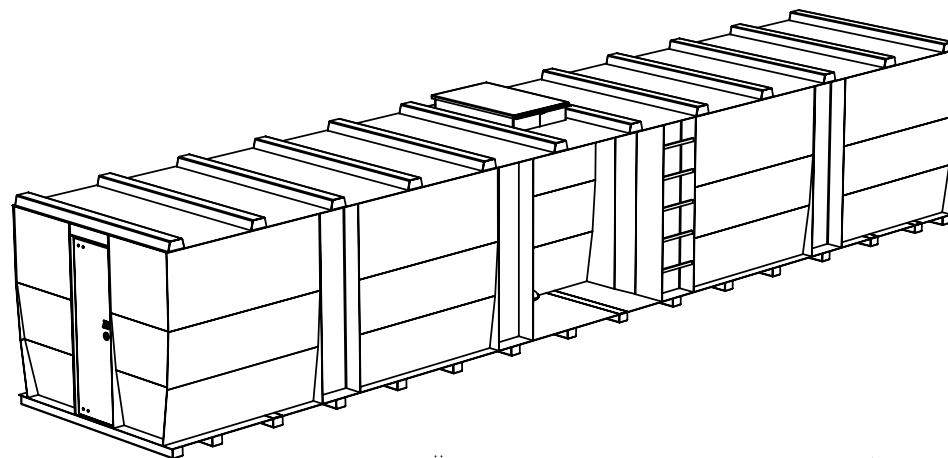
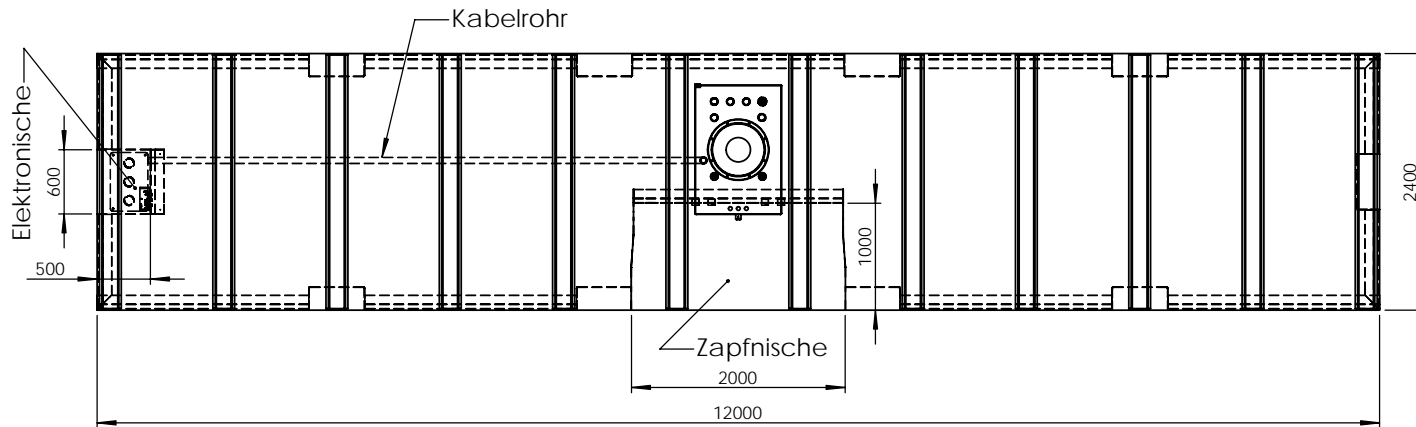
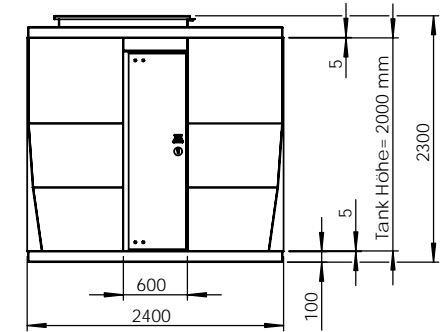
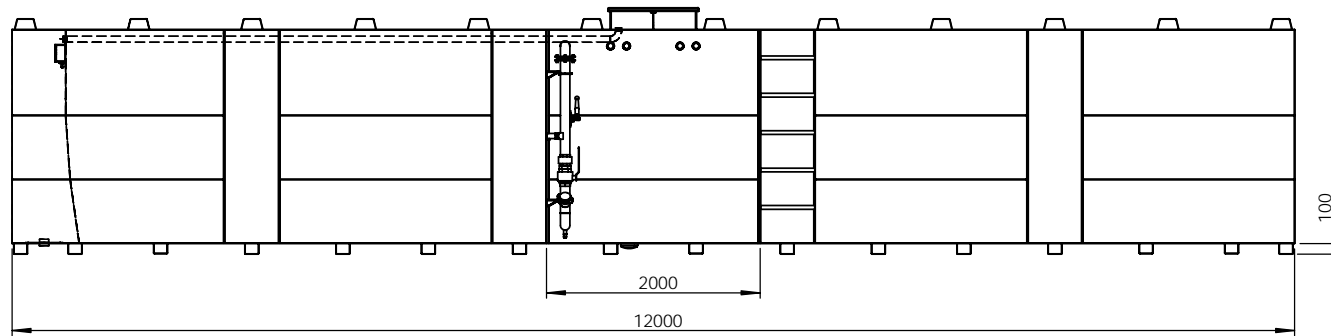

KTM-50.000 Tankstelle
doppelwandig aus Stahl
zur Lagerung von Diesel
zur Aussenauflistung

Medium: Diesel

Länge: 12.000 mm
Breite: 2.400 mm
Höhe: 2.000 mm

Nettvolumen: 45.500 Ltr.
Gewicht: ca. 8.800 kg

Technische Änderungen bleiben vorbehalten! / Change reserve!

UNLESS OTHERWISE SPECIFIED: DIMENSIONS ARE IN MILLIMETERS SURFACE FINISH: TOLERANCES:		FINISH:		DEBUR AND BREAK SHARP EDGES		SCALE: 1:50	WEIGHT:
						MATERIAL: S235 JRG2 EN 100 25	
DRAWN	NAME	SIGNATURE	DATE	TIME	TITLE:		
CHK'D	Krisko		Freitag, 11. August 2006 14:04:22		2D-Ansichten KTM-50.000 Tankstelle doppelwandig		
APPV'D					DWG NO.		
MFG					A3		
Q.A					REVISION		
						SHEET 1 OF 3	

Füllhöhe = 95% der Tankinnenhöhe! / Body stand = 95 % middle high of tank!

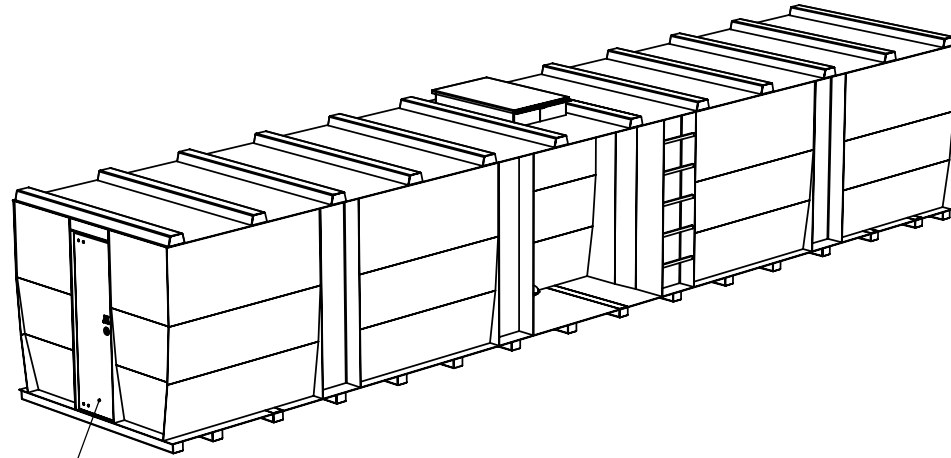

Tür (Verschlußmöglichkeit optional!)

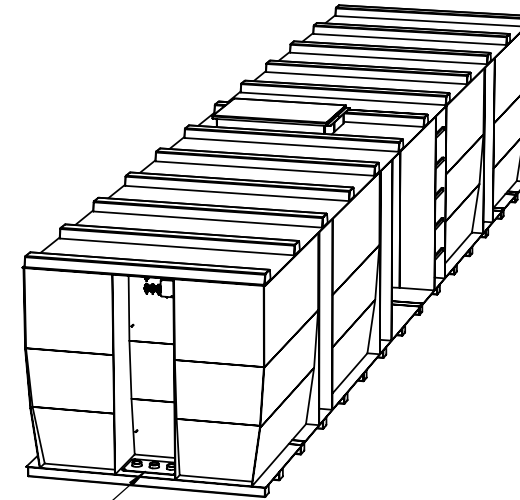

Funktionsnische Stirnseite: (Elektronische)
Breite: 600 mm,
Tiefe: 500 mm.

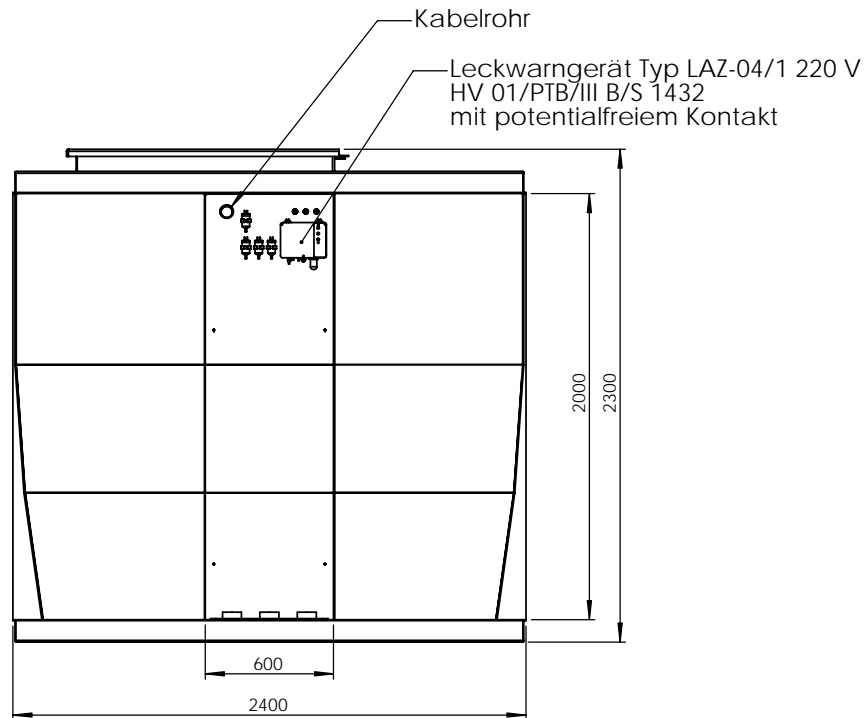

UNLESS OTHERWISE SPECIFIED: DIMENSIONS ARE IN MILLIMETERS SURFACE FINISH:		FINISH:		DEBUR AND BREAK SHARP EDGES		SCALE: 1:50	WEIGHT:
TOLERANCES:						MATERIAL: S235 JRG2 EN 100 25	
DRAWN	NAME	SIGNATURE	DATE	TIME	TITLE:		
	Krisko		Freitag, 11. August 2006 14:04:22		Ansicht Elektronische KTM-50.000 Tankstelle doppelwandig		
CHK'D					DWG NO.		
APPV'D					A3		
MFG					REVISION		
O.A.					SHEET 2 OF 3		

Technische Änderungen bleiben vorbehalten! / Change reserve!

Krampitz
www.TANKSYSTEM.de

Füllhöhe = 95% der Tankinnenhöhe! / Body stand = 95 % middle high of tank!

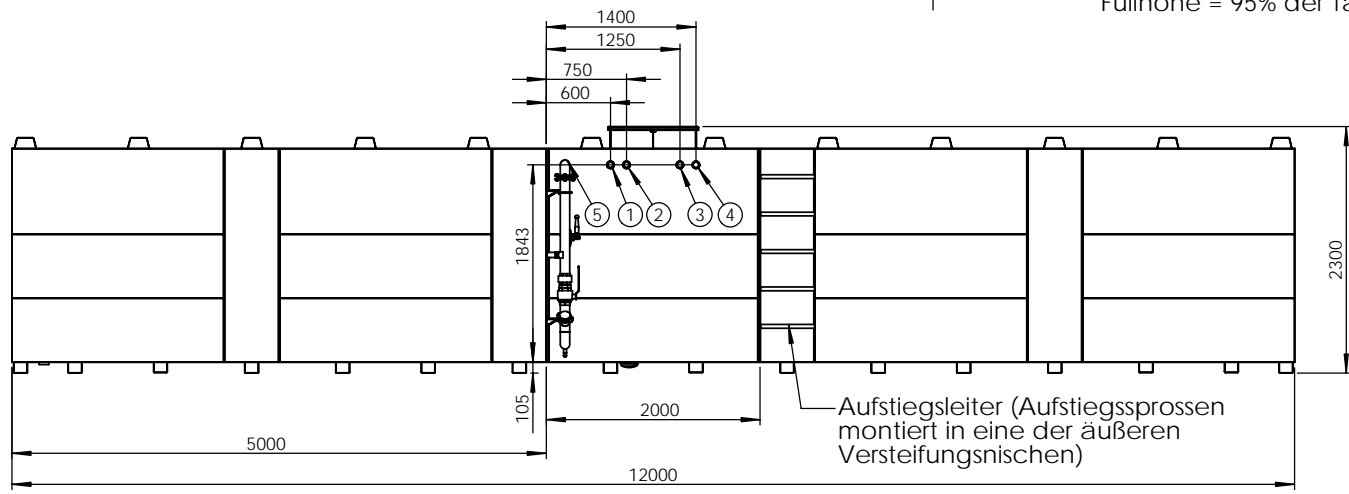

Pos. Zapfnische:

- 01 - Saugleitung - Muffe DN50
- 02 - Rücklaufleitung - Muffe DN50
- 03 - Rücklaufleitung - Muffe DN50
- 04 - Saugleitung - Muffe DN50
- 05 - Befüllsystem für Tankwagen DN80

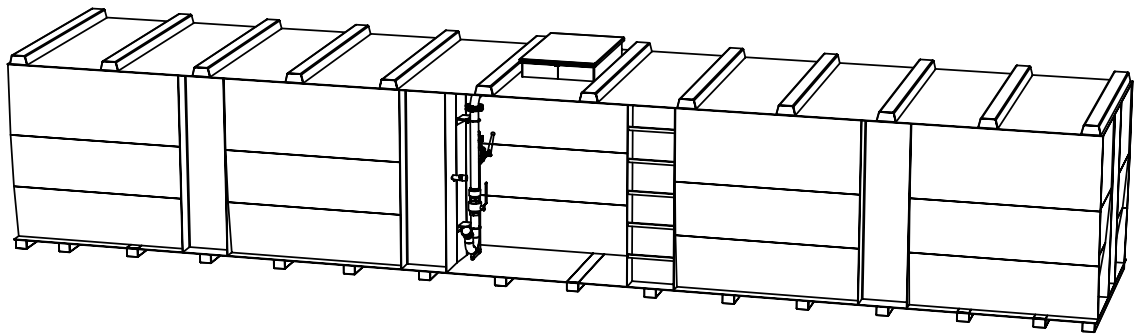
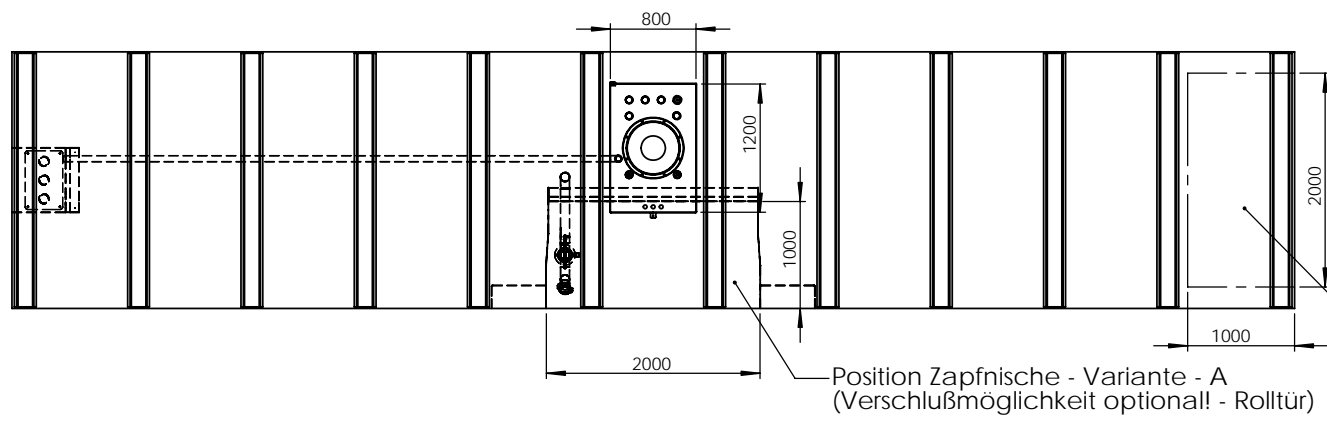

Technische Änderungen bleiben vorbehalten! / Change reserve!

UNLESS OTHERWISE SPECIFIED: DIMENSIONS ARE IN MILLIMETERS SURFACE FINISH: TOLERANCES:		FINISH:	DEBUR AND BREAK SHARP EDGES		SCALE: 1:50	WEIGHT:
					MATERIAL: S235 JRG2 EN 100 25	
					TITLE: Ansicht Zapfnische KTM-50.000 Tankstelle doppelwandig	
DRAWN: Krisko		SIGNATURE:	DATE: Freitag, 11. August 2006 14:04:22	TIME:	DWG NO.	
CHK'D:					A3	
APPV'D:						
MFG:						
O.A:						
				REVISION		SHEET 3 OF 3

